

COPYRIGHT, 1910, BY THE

# Westinghouse Traction Brake Company



## Whistles, Whistle Valves and Accessories

Part Catalog No. T 3517-1

March, 1918

(SUPERSEDING ISSUE OF SEPTEMBER, 1910)

CLARION WHISTLE

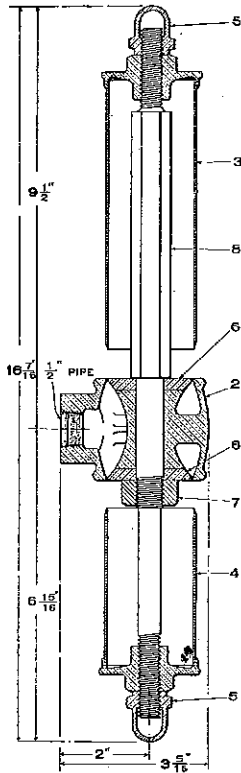

Net Weight, 5 lbs.

Piece No. 19046. Clarion Whistle, complete . List Price, \$6.00

Pc. No.	Ref. No.	List Price
18821	2 Body . . . . .	\$.1.25
18823	3 Long Whistle Bowl, complete . . . . .	1.10
18825	4 Short Whistle Bowl, complete . . . . .	1.00
18827	5 Lock Nut for Whistle Stem . . . . .	.20
18828	6 Disc . . . . .	.30
2519	7 Nut . . . . .	.05
18820	8 Stem . . . . .	1.50

TROMBONE WHISTLE

Piece No. 21313. Trombone Whistle, complete . . . . List Price, \$3.00

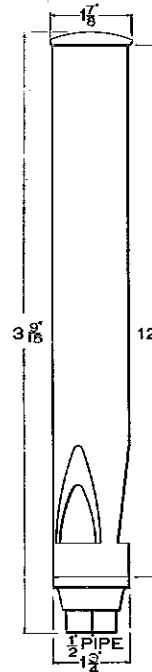

Net Weight, 3 1/4 lbs.

Orders must give PIECE NUMBER and NAME of part wanted.

WHISTLE VALVES

Improved Type of Whistle Valves having thimble and seat to prevent the leakage of air when the valve is open.

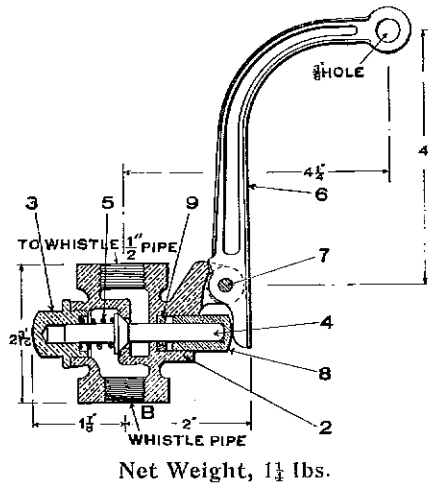

Piece No. 31422.  $\frac{1}{2}$ " x  $\frac{3}{8}$ " Whistle Valve, complete with Handle List Price, \$1.40

Piece No. 31418.  $\frac{1}{2}$ " x  $\frac{1}{2}$ " Whistle Valve, complete with Handle List Price, \$1.40

Pc. No.	Ref. No.	Description	List Price
30212	2	$\frac{1}{2}$ " x $\frac{3}{8}$ " Body (includes 3)	\$.80
30211	2	$\frac{1}{2}$ " x $\frac{1}{2}$ " Body (includes 9)	.80
3501	3	Cap Nut	.20
3500	4	Valve	.12
†3503	5	Spring	.03
31406	6	Handle	.10
3504	7	Fillister Head Screw	.01
31415	8	Thimble	.15
31416	9	Thimble Seat	*

Old Style Whistle Valves are no longer furnished, but are listed for convenience in ordering repair parts only.

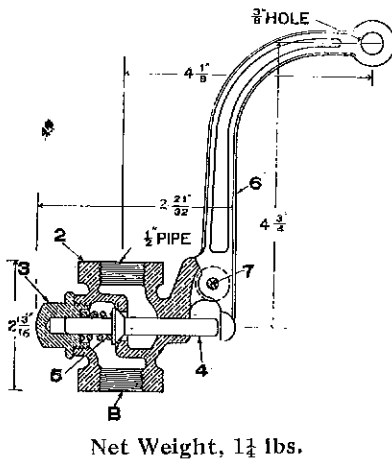

Piece No. 16894.  $\frac{1}{2}$ " x  $\frac{3}{8}$ " Whistle Valve, complete with Handle List Price, \$1.25

Piece No. 8046.  $\frac{1}{2}$ " x  $\frac{1}{2}$ " Whistle Valve, complete with Handle List Price, \$1.25

Pc. No.	Ref. No.	Description	List Price
16879	2	$\frac{1}{2}$ " x $\frac{3}{8}$ " Body	\$.80
3499	2	$\frac{1}{2}$ " x $\frac{1}{2}$ " Body	.80
3501	3	Cap Nut	.20
3500	4	Valve	.12
†3503	5	Spring	.03
8045	6	Handle	.10
3504	7	Fillister Head Screw	.01

WHISTLE VALVE HANDLES

These Special Handles can be applied to either of the whistle valves listed above and will be furnished if desired and order so specifies, without additional charge.

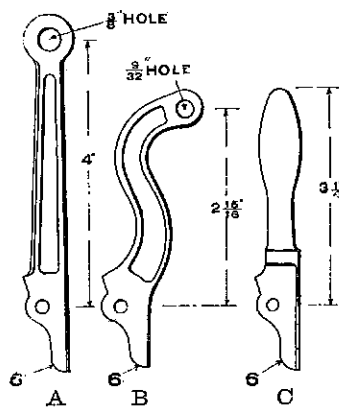

Pc. No.	Ref. No.	Description	List Price
31408	6	Handle A	\$.10
31407	6	Handle B	.10
31413	6	Handle C	.10

\*NOTE A—See Part Catalog T 3516-10.

†NOTE B—For Spring Identification Table, see page 5.

Orders must give PIECE NUMBER and NAME of part wanted.

DUPLEX CHECK VALVE

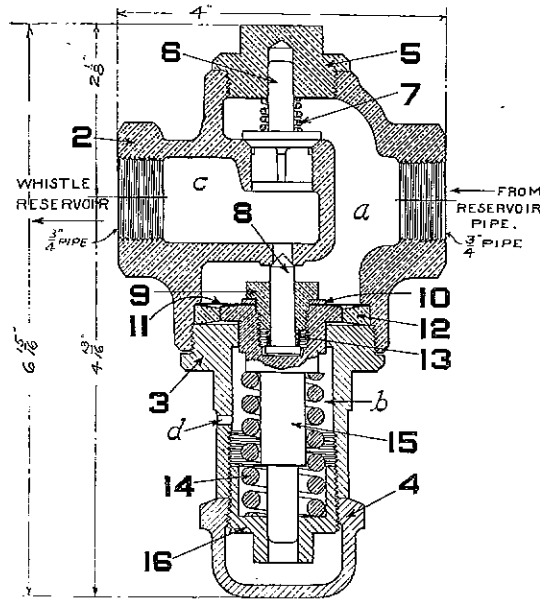

Net Weight, 5 1/4 lbs.

A Duplex Check Valve is occasionally used between the Main Reservoir and Whistle Reservoir to prevent undesirable reduction in Main Reservoir pressure due to excessive use of the whistle.

Piece No. 5143<sup>†</sup> Duplex Check Valve, complete . . . . . List Price, \$5.00

Pc. No.	Ref. No.		List Price
5139	2	Valve Body . . . . .	\$2.50
5163	3	Spring Box . . . . .	.40
1067	4	Check Nut . . . . .	.15
5140	5	Cap Nut . . . . .	.25
5141	6	Valve . . . . .	.25
†5419	7	Spring for Valve . . . . .	.02
5420		Diaphragm, complete (includes 8, 9, 10, 13, 15 and two of 11) . . . . .	.75
5299	8	Diaphragm Valve . . . . .	.06
5297	9	Diaphragm Nut . . . . .	.20
5298	10	Diaphragm Washer . . . . .	.05
19904	11	Diaphragm (2 pieces) . . . . .	.10
1064	12	Diaphragm Ring . . . . .	.15
†5301	13	Diaphragm Valve Spring . . . . .	.02
†1068	14	Regulating Spring . . . . .	.15
5142	15	Diaphragm Spindle . . . . .	.35
11261	16	Regulating Nut . . . . .	.15

3/8-INCH CHOKE FITTING

A 3/8" Choke Fitting is occasionally used between the Main Reservoir and the Whistle Reservoir to prevent sudden and undesirable variations in main reservoir pressure due to use of the whistle.

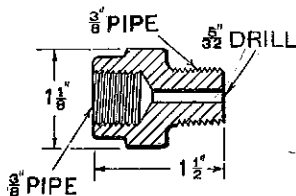

Piece No. 18877. 3/8" Choke Fitting with 5/32" hole, complete . . . . . List Price, \$ .10

†NOTE—For Spring Identification Table, see page 5.

Orders must give PIECE NUMBER and NAME of part wanted.

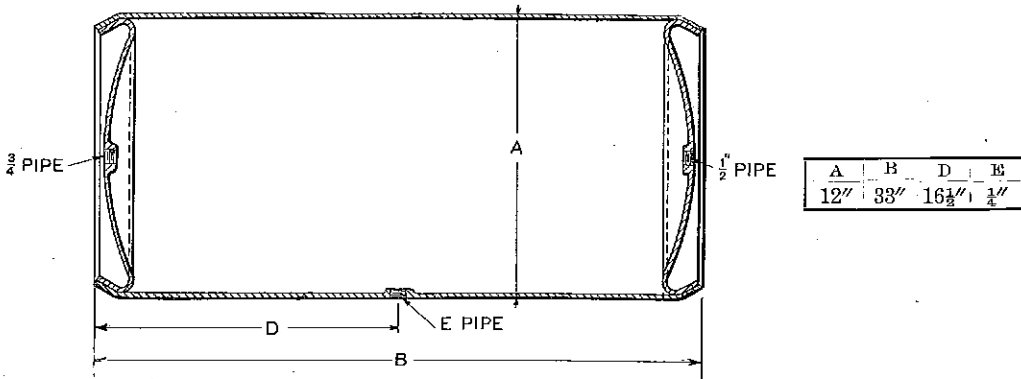

Net Weight, 90 lbs.

Piece No. 3093. 12" x 33" Whistle Reservoir . . . . . List Price, \$6.50

RESERVOIR HANGER AND BLOCK

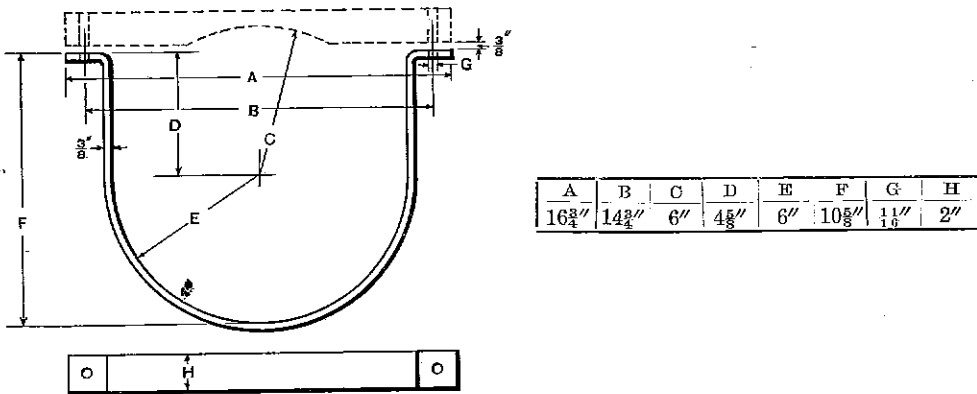

Net Weight, 7 1/4 lbs.

Pc. No.		List Price
20527	12" Reservoir Hanger and Block, complete . . . . .	\$.75
16904	12" Reservoir Hanger . . . . .	.50
16915	12" Reservoir Block . . . . .	.25

RESERVOIR DRAIN COCK

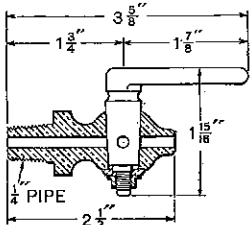

Net Weight, 1/2 lb.

Piece No. 41814. 1/4" Auxiliary Reservoir Drain  
Cock . . . . . List Price, \$ .40

The following table is shown to enable railway storekeepers and air brake men to identify the springs used in the Valves cataloged herein. This table does not represent a specification for the springs in question and should not be used as such. As a further assistance to storekeepers, the springs are packed in small lots with a tag attached to each lot bearing the proper piece number.

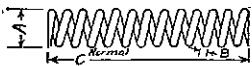

SPRING IDENTIFICATION

Pc. No.	Out. Dia. "A"	Dia. Wire "B"	Free Height "C"	No. Coils	Material	Name of Spring	Where Used
3503	1 1/2"	.072"	3 3/8"	4 1/4	Phos. Bronze	Valve	Whistle Valves
5419	1 1/8"	.036"	3 3/8"	5	Phos. Bronze	Valve	Duplex Check Valve
1068	1"	.22 "	2"	6 1/4	Steel	Regulating	Duplex Check Valve
5301	1 3/8"	.049"	1 3/8"	4	Brass	Diaphragm Valve	Duplex Check Valve

Orders must give PIECE NUMBER and NAME of part wanted.

# Westinghouse Traction Brake Company,

Pittsburgh, Pa., U. S. A.

WORKS AT WILMERDING, PA.

OFFICES:

ATLANTA	-	-	-	-	-	-	-	-	-	Candler Building
BOSTON	-	-	-	-	-	-	-	-	-	Exchange Building
CHICAGO	-	-	-	-	-	-	-	-	-	Railway Exchange Building
COLUMBUS	-	-	-	-	-	-	-	-	-	Columbus Savings and Trust Building
DENVER	-	-	-	-	-	-	-	-	-	Tramway Building
HOUSTON, TEX.	-	-	-	-	-	-	-	-	-	4802 Main Street
LOS ANGELES	-	-	-	-	-	-	-	-	-	Pacific Electric Building
MEXICO CITY, MEXICO	-	-	-	-	-	-	-	-	-	4a Puente de Alvarado, No. 100
NEW YORK	-	-	-	-	-	-	-	-	-	City Investing Building
PITTSBURGH	-	-	-	-	-	-	-	-	-	Westinghouse Building
ST. LOUIS	-	-	-	-	-	-	-	-	-	Boatmen's Bank Building
ST. PAUL	-	-	-	-	-	-	-	-	-	Endicott Building
SALT LAKE CITY	-	-	-	-	-	-	-	-	-	McIntyre Building
SAN FRANCISCO	-	-	-	-	-	-	-	-	-	Southern Pacific Building
SEATTLE	-	-	-	-	-	-	-	-	-	Securities Building
TOPEKA	-	-	-	-	-	-	-	-	-	New England Building

Form 49.

**THE MUNICIPAL TRAMWAYS TRUST, ADELAIDE.**

Date Received \_\_\_\_\_ No. \_\_\_\_\_

Section 5 Published \_\_\_\_\_

Contents Westinghouse Brake  
Details

Refer Letter Dated \_\_\_\_\_

Agent Westinghouse Traction Brake

Address Pittsburgh, Pa. U.S.A. Co.

wo52636

WESTINGHOUSE AIR BRAKE COMPANY,  
Pittsburgh, Pa.

THE AMERICAN BRAKE COMPANY,  
St. Louis, Mo.

THE WESTINGHOUSE BRAKE COMPANY, LTD.,  
London, England.

WESTINGHOUSE PACIFIC COAST BRAKE  
COMPANY,  
Emeryville, Calif.

WESTINGHOUSE BRAKE COMPANY OF  
AUSTRALASIA, LTD.,  
Concord West, New South Wales, Australia.

CANADIAN WESTINGHOUSE COMPANY, LTD.,  
Hamilton, Ontario, Canada.

SOCIETE ANONYME WESTINGHOUSE,  
Petrograd, Russia.

COMPAGNIE DES FREINS WESTINGHOUSE,  
Sevran, France.

COMPAGNIA ITALIANA WESTINGHOUSE  
DEI FRENI,  
Turin, Italy.

WESTINGHOUSE EISENBAHN BREMSEN.  
GESELLSCHAFT,  
Hanover, Germany.